



**Pressure regulating valve T95**  
without auxiliary power, for liquids and gases  
PN40 DN15-40 (1/2" - 1 1/2")

**Schley Armaturen GmbH**  
VALVE MANUFACTURING  
Carl-Backhaus-Straße 3  
D-22926 Ahrensburg  
Tel: +49 4102 77883-0 • Fax: +49 4102 77883-99

## Downstream pressure controlled regulator without auxiliary power, Model T95

The task of pressure regulating valves is to control a varying or constant upstream pressure of a medium to a reduced outlet pressure.

The regulator, model T 95, is suitable for compressible media, such as compressed air, natural gas and for incompressible media such as water and oil, etc.

Pressure reduction occurs by throttling the free cross-section between the seat and the cone. Any change in pressure on the downstream pressure side is immediately converted into a displacement of the valve cone. With zero load, i. e. when the load on the downstream pressure side is zero, the valve does seal tightly by a pressure rise of 0,5 bar on the downstream side.

With the model T 95 the max. reduction ratio of 25 : 1 should not be exceeded.

The lowest downstream pressure is 1 bar (under 1 bar only with enlarged control unit), highest downstream pressure is 10 bar.

### Mass flow:

A mass flow graph for compressed air at 0°C is given on page 4. A prerequisite is critical flow, i.e. low pressure  $p_2$  (bar<sub>abs</sub>) / high pressure  $p_1$  (bar<sub>abs</sub>) = 0.527

With non-critical flow the indicated forward flow must be multiplied with an appropriate multiplier.

$\frac{p_2}{p_1}$ bar <sub>abs</sub>	0.60	0.70	0.80	0.85	0.90
Multiplier	1	0.933	0.819	0.733	0.617

**The velocity of the compressed air in the pipe-work must not exceed 20 m/s.**

Examples :

Compressed air :  $p_1 = 9 \text{ bar}$  ;  $p_2 = 3 \text{ bar}$

$$\frac{p_2}{p_1} = \frac{4 \text{ bar}_{\text{abs}}}{10 \text{ bar}_{\text{abs}}} = 0.4 \leq \text{critical}, Q = 2700 \frac{\text{m}^3}{\text{h}}$$

Air at 0°C and 1013 mbar

A line gives a regulator *DN 50*

Piping : for 270 m<sup>3</sup>/h and ~ 20 m/s = *DN 65*

A mass flow graph is given for water at 20°C on page 5. **The velocity of the water in the piping must not exceed 2 m/s.**

Water :  $p_1 = 9 \text{ bar}$  ;  $p_2 = 6 \text{ bar}$

$$\Delta p = 3 \text{ bar}_{\text{abs}} ; G = 60 \text{ m}^3/\text{h}$$

A line gives a regulator *DN 65*

Piping : for 60 m<sup>3</sup>/h and ~ 2 m/s = *DN 100*

For enquiries and orders we would like the following details :

- Upstream pressure
- Downstream pressure (reduced pressure)
- Medium
- Temperature
- Mass flow (forward flow)

### Installation notes :

A strainer should normally be installed in the upstream pressure line. Dirt between the seat and cone prevents proper sealing for zero consumption, particularly with compressed air due to the narrow gaps between the seat and cone. It is practicable to install a shut-off valve on the upstream pressure side.



## Pressure regulating valve T95

without auxiliary power, for liquids and gases  
PN40 DN15-40 (1/2" - 1 1/2")

Schley Armaturen GmbH

VALVE MANUFACTURING

Carl-Backhaus-Straße 3

D-22926 Ahrensburg

Tel: +49 4102 77883-0 • Fax: +49 4102 77883-99

### IMPORTANT!

It is essential to install a safety valve on the exit side to protect the loads.

With incompressible media the safety valve must be dimensioned such that the flow to the upstream pressure side of the regulator can be passed.

With compressible media the volume given by the flow on the upstream pressure side and the reduction ratio must be able to be passed.

The regulator must be fitted as closely as possible to the loads. Long lengths of piping on the reduced pressure side impair the regulation.

#### Mounting direction:

The arrow cast on the valve housing must point to the reduced pressure side.

The medium must enter from below the cone. A pulse line does not need to be provided by the customer since this is available on the regulator. However, if required, the pulse line can be routed closer to the loads by the customer.

It has been found practicable to implement the approach and tail distances straight (10 x pipe diameter) so that, where possible, no turbulences, which may affect pressure regulation, occur in front of and behind the regulator.

The regulator can be mounted in any position. With contaminated media fit the regulator horizontally in the piping with the spring hood at the top.

Setting ranges of the downstream pressure and corresponding spring-no.

bar from - to	15/20	DN 25	32-40
0.40 - 0.63	103	103	8
0.63 - 1.00	104	104	7
1.00 - 1.60	105	105	6
1.60 - 2.50	106	106	5
2.50 - 4.00	107	107	4
4.00 - 6.30	108	108	3
6.30 - 10.00	109	109	2

Lower and higher downstream pressures than those specified need special control units.

Versions :

T 95 in G-CuSn10 (Bronze),  
- cone with compressible seal DIN PN 40

With temperatures over 100°C a metal cone seal is used.

For gases other than air multiplication with the following medium factor is used :

Ammonia	= 0.788
Argon	= 1.105
Ethylene	= 1.029
Acetylene	= 0.997
Chlorine	= 1.600
Helium	= 0.351
Carbon dioxide	= 1.265
Carbon monoxide	= 0.983
Coal gas	= 0.640
Air	= 1.000
Methane	= 0.763
Oxygen	= 1.051
Sulphur dioxide	= 1.504
Nitrogen	= 0.983
Hydrogen	= 0.263

For reference quantities other than 0°C and 760 Torr multiply by :

760 Torr	0°C	= 1.000
760 Torr	20°C	= 0.932
1 bar <sub>abs</sub>	20°C	= 0.902
1 bar <sub>abs</sub>	0°C	= 0.968

For operating temperatures other than °C multiply by :

$$\text{Factor} = \sqrt{\frac{t + 273}{273}}$$

t in [°C]	0 - 10	11 - 50	51 - 100	101 - 150	151 - 200
Factor	1.00	1.10	1.20	1.25	1.32



**Pressure regulating valve T95**  
without auxiliary power, for liquids and gases  
PN40 DN15-40 (1/2" - 1 1/2")

**Schley Armaturen GmbH**  
VALVE MANUFACTURING  
Carl-Backhaus-Straße 3  
D-22926 Ahrensburg  
Tel: +49 4102 77883-0 • Fax: +49 4102 77883-99

**Model T95**

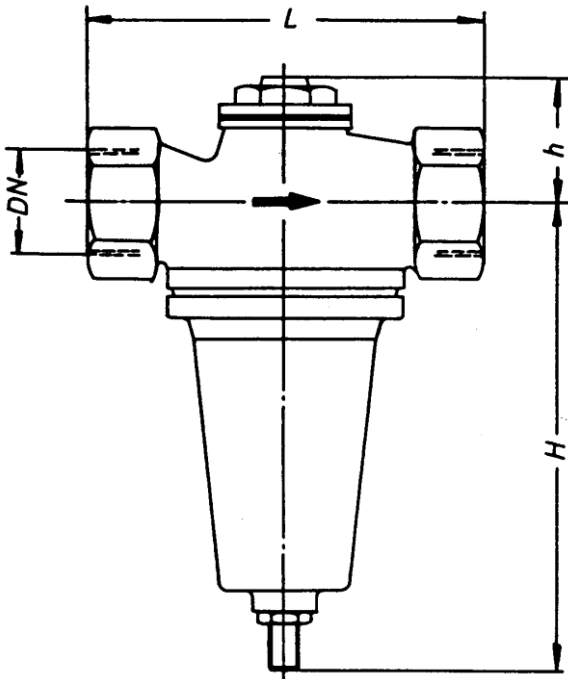

Type socket  
DN15 – DN50

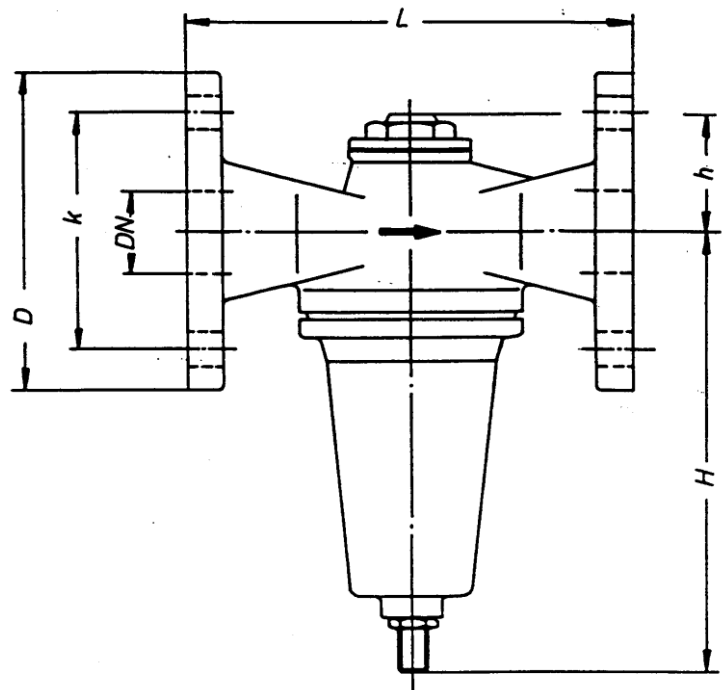

Type flanges  
DN15 – DN50

Designation of a pressure reducing valve of nominal size DN 25 :

**Pressure reducing valve T95 DN25**

DN	Socket				Flanges PN40						
	R	L	H	h	D	k	z	i	L	H	h
15	1/2"	110	125	35	95	65	4	14	130	125	35
20	3/4"	110	125	35	105	75	4	14	150	145	40
25	1"	110	145	40	115	85	4	14	160	145	40
32	1 1/4"	150	170	50	140	100	4	18	180	170	50
40	1 1/2"	200	195	60	150	110	4	18	200	195	60
50	2"	200	195	60	165	125	4	18	230	195	60

Dimensions in mm

Material: **G-CuSn10** for DN15-50



# Pressure regulating valve T95

without auxiliary power, for liquids and gases  
PN40 DN15-40 (1/2" - 1 1/2")

Schley Armaturen GmbH  
VALVE MANUFACTURING  
Carl-Backhaus-Straße 3  
D-22926 Ahrensburg  
Tel: +49 4102 77883-0 • Fax: +49 4102 77883-99

## Flow graph for T95 (gas)

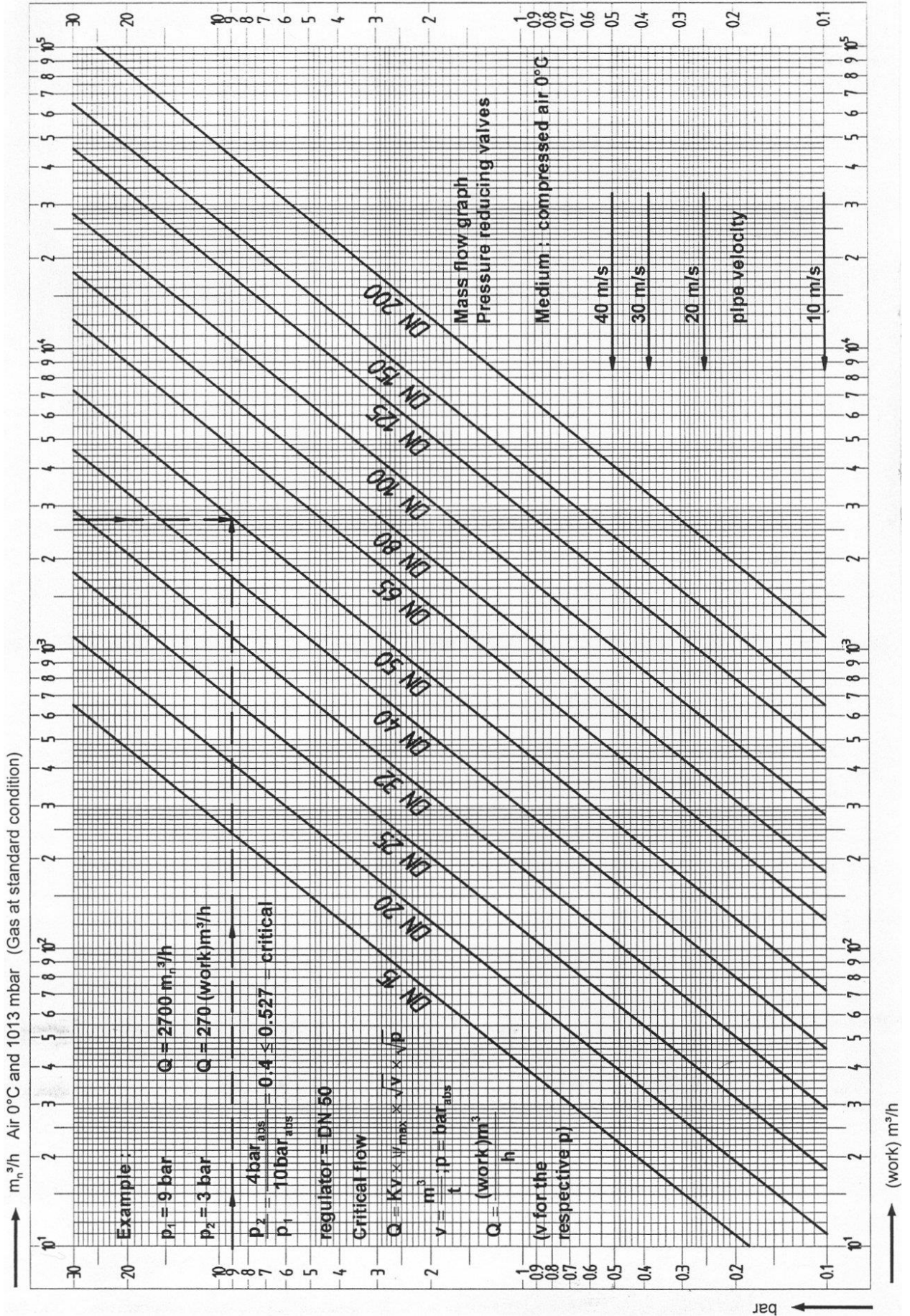



# Pressure regulating valve T95

without auxiliary power, for liquids and gases  
PN40 DN15-40 (1/2" - 1 1/2")

Schley Armaturen GmbH  
VALVE MANUFACTURING  
Carl-Backhaus-Straße 3  
D-22926 Ahrensburg  
Tel: +49 4102 77883-0 • Fax: +49 4102 77883-99

## Flow graph for T95 (liquid)

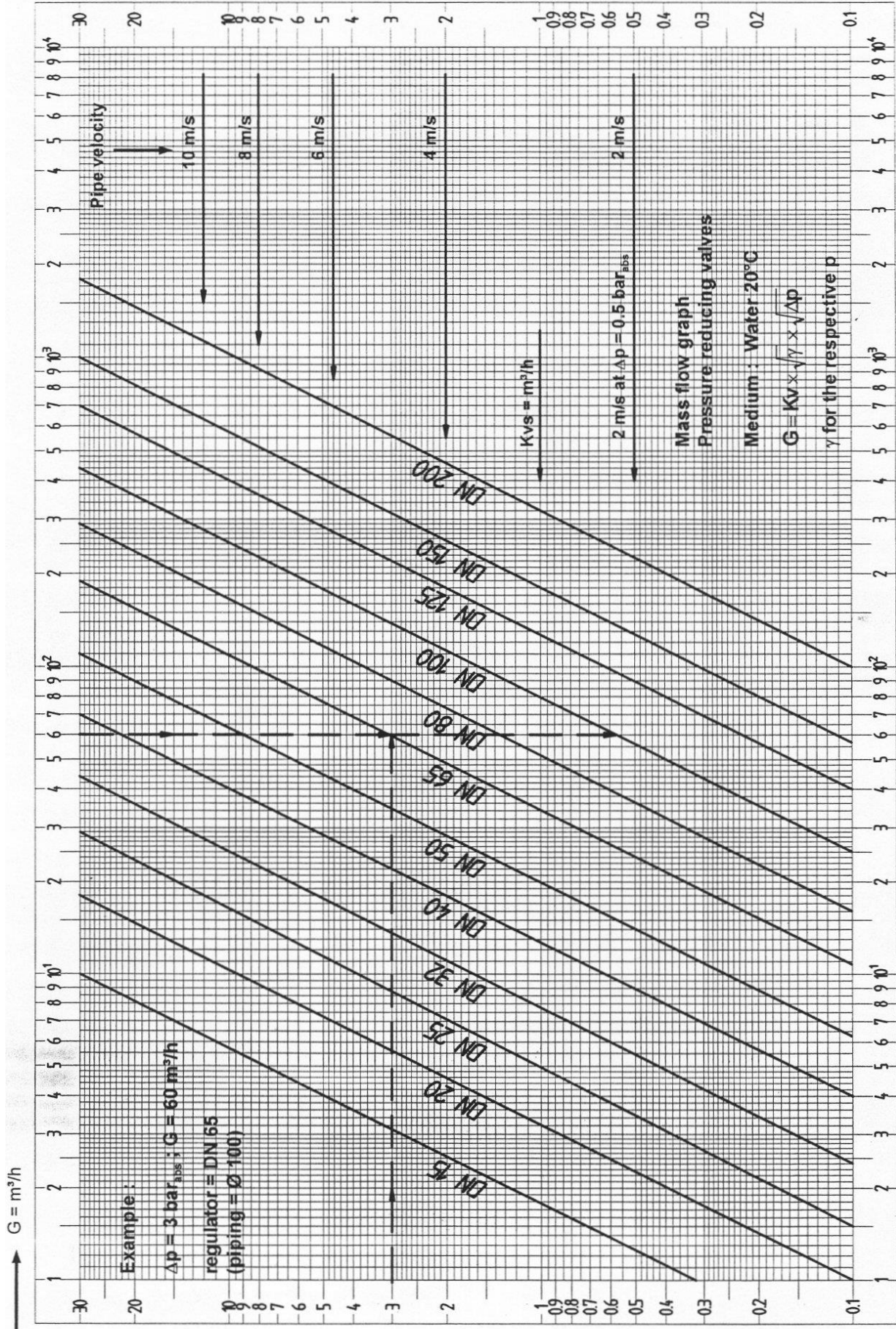



## Pressure regulating valve T95

without auxiliary power, for liquids and gases  
PN40 DN15-40 (1/2" - 1 1/2")

**Schley Armaturen GmbH**

VALVE MANUFACTURING

Carl-Backhaus-Straße 3

D-22926 Ahrensburg

Tel: +49 4102 77883-0 • Fax: +49 4102 77883-99