



## Pressure regulating valve T9

without auxiliary power, for liquids and gases  
DN15-200 PN16-40

Schley Armaturen GmbH  
VALVE MANUFACTURING  
Carl-Backhaus-Straße 3  
D-22926 Ahrensburg  
Tel: +49 4102 77883-0 • Fax: +49 4102 77883-99

# Downstream pressure-controlled regulator without auxiliary power, Model T9

The task of downstream pressure controlled regulators (pressure regulating valves) is to control a varying or constant upstream pressure of a medium to a constant outlet pressure (reduced pressure) which is independent of the upstream pressure.

The regulator, model T 9, is suitable for compressible media, such as compressed air, natural gas and for incompressible media such as water and oil, etc.

Regulation (pressure reduction) occurs by throttling the free cross-section between the seat and the cone. The downstream pressure presses on the differential piston via a pulse line. This means that any change in pressure on the exit side is immediately converted into a displacement of the valve cone. The regulator is well suited to intermittent applications. With zero consumption on the exit side, the regulator closes reliably through a slight rise in pressure.

With the model T 9 the max. reduction ratio of 25 : 1 should not be exceeded.

The lowest downstream pressure is 0.5 bar (under 0.5 bar only with enlarged control unit), highest downstream pressure is 10 bar.

### Mass flow:

A mass flow graph for compressed air at 0°C is given on page 4. A prerequisite is critical flow, i.e. low pressure  $p_2$  (bar<sub>abs</sub>) / high pressure  $p_1$  (bar<sub>abs</sub>) = 0.527

With non-critical flow the indicated forward flow must be multiplied with an appropriate multiplier.

$\frac{p_2}{p_1}$ bar <sub>abs</sub>	0.60	0.70	0.80	0.85	0.90
Multiplier	1	0.933	0.819	0.733	0.617

**The velocity of the compressed air in the pipe-work must not exceed 20 m/s.**

Examples :

Compressed air :  $p_1 = 9 \text{ bar}$  ;  $p_2 = 3 \text{ bar}$

$$\frac{p_2}{p_1} = \frac{4 \text{ bar}_{\text{abs}}}{10 \text{ bar}_{\text{abs}}} = 0.4 \leq \text{critical}, Q = 2700 \frac{\text{m}^3}{\text{h}}$$

Air at 0°C and 1013 mbar

A line gives a regulator *DN 50*

Piping : for 270 m<sup>3</sup>/h and ~ 20 m/s = *DN 65*

A mass flow graph is given for water at 20°C on page 5. **The velocity of the water in the piping must not exceed 2 m/s.**

Water :  $p_1 = 9 \text{ bar}$  ;  $p_2 = 6 \text{ bar}$

$$\Delta p = 3 \text{ bar}_{\text{abs}} ; G = 60 \text{ m}^3/\text{h}$$

A line gives a regulator *DN 65*

Piping : for 60 m<sup>3</sup>/h and ~ 2 m/s = *DN 100*

For enquiries and orders we would like the following details :

- Upstream pressure
- Downstream pressure (reduced pressure)
- Medium
- Temperature
- Mass flow (forward flow)

### Installation notes :

A strainer should normally be installed in the upstream pressure line. Dirt between the seat and cone prevents proper sealing for zero consumption, particularly with compressed air due to the narrow gaps between the seat and cone. It is practicable to install a shut-off valve on the upstream pressure side.



## Pressure regulating valve T9

without auxiliary power, for liquids and gases  
DN15-200 PN16-40

**Schley Armaturen GmbH**  
VALVE MANUFACTURING  
Carl-Backhaus-Straße 3  
D-22926 Ahrensburg  
Tel: +49 4102 77883-0 • Fax: +49 4102 77883-99

### IMPORTANT!

It is essential to install a safety valve on the exit side to protect the loads.

With incompressible media the safety valve must be dimensioned such that the flow to the upstream pressure side of the regulator can be passed.

With compressible media the volume given by the flow on the upstream pressure side and the reduction ratio must be able to be passed.

The regulator must be fitted as closely as possible to the loads. Long lengths of piping on the reduced pressure side impair the regulation.

### Mounting direction:

The arrow cast on the valve housing must point to the reduced pressure side.

The medium must enter from below the cone. A pulse line does not need to be provided by the customer since this is available on the regulator. However, if required, the pulse line can be routed closer to the loads by the customer.

It has been found practicable to implement the approach and tail distances straight (10 x pipe diameter) so that, where possible, no turbulences, which may affect pressure regulation, occur in front of and behind the regulator.

The regulator can be mounted in any position. With contaminated media fit the regulator horizontally in the piping with the spring hood at the top.

Setting ranges of the downstream pressure and corresponding spring-no.

bar from - to	DN				
	15-40	50/65	80/100	125/150	200
0.40 - 0.63	7	27	38	47	46
0.63 - 1.00	6	26	37	46	45
1.00 - 1.60	5	25	36	45	44
1.60 - 2.50	4	24	35	44	43
2.50 - 4.00	3	23	34	43	42
4.00 - 6.30	2	22	33	42	41
6.30 - 10.00	1	21	32	41	41 (180°)

Lower and higher downstream pressures than those specified need special control units.

### Versions :

0.7040 / EN-JS1030	DIN PN16
1.0619 / GP240GH	DIN PN40
1.4408 / GX5CrNiMo19-11-2	DIN PN40
1.4410 / GX2CrNiMoN25-7-4	DIN PN40

- Seat, cone and cone-rod in stainless steel

2.1050 / CC480K	DIN PN40
-----------------	----------

- Seat, cone and cone-rod in bronze

With temperatures over 100°C a metal cone seal is used.

DN 125 - 200 needs a special dimension drawing.

For gases other than air multiplication with the following medium factor is used :

Ammonia	= 0.788
Argon	= 1.105
Ethylene	= 1.029
Acetylene	= 0.997
Chlorine	= 1.600
Helium	= 0.351
Carbon dioxide	= 1.265
Carbon monoxide	= 0.983
Coal gas	= 0.640
Air	= 1.000
Methane	= 0.763
Oxygen	= 1.051
Sulphur dioxide	= 1.504
Nitrogen	= 0.983
Hydrogen	= 0.263

For reference quantities other than 0°C and 760 Torr multiply by :

760 Torr	0°C	= 1.000
760 Torr	20°C	= 0.932
1 bar <sub>abs</sub>	20°C	= 0.902
1 bar <sub>abs</sub>	0°C	= 0.968

For operating temperatures other than °C multiply by :

$$\text{Factor} = \sqrt{\frac{t+273}{273}}$$

t in [°C]	0 - 10	11 - 50	51 - 100	101 - 150
Factor	1.00	1.10	1.20	1.25
151 - 200	201 - 250	251 - 300	301 - 350	351 - 400
1.32	1.40	1.45	1.50	1.57



## Pressure regulating valve T9

without auxiliary power, for liquids and gases  
DN15-200 PN16-40

Schley Armaturen GmbH  
VALVE MANUFACTURING  
Carl-Backhaus-Straße 3  
D-22926 Ahrensburg  
Tel: +49 4102 77883-0 • Fax: +49 4102 77883-99

### Model T9

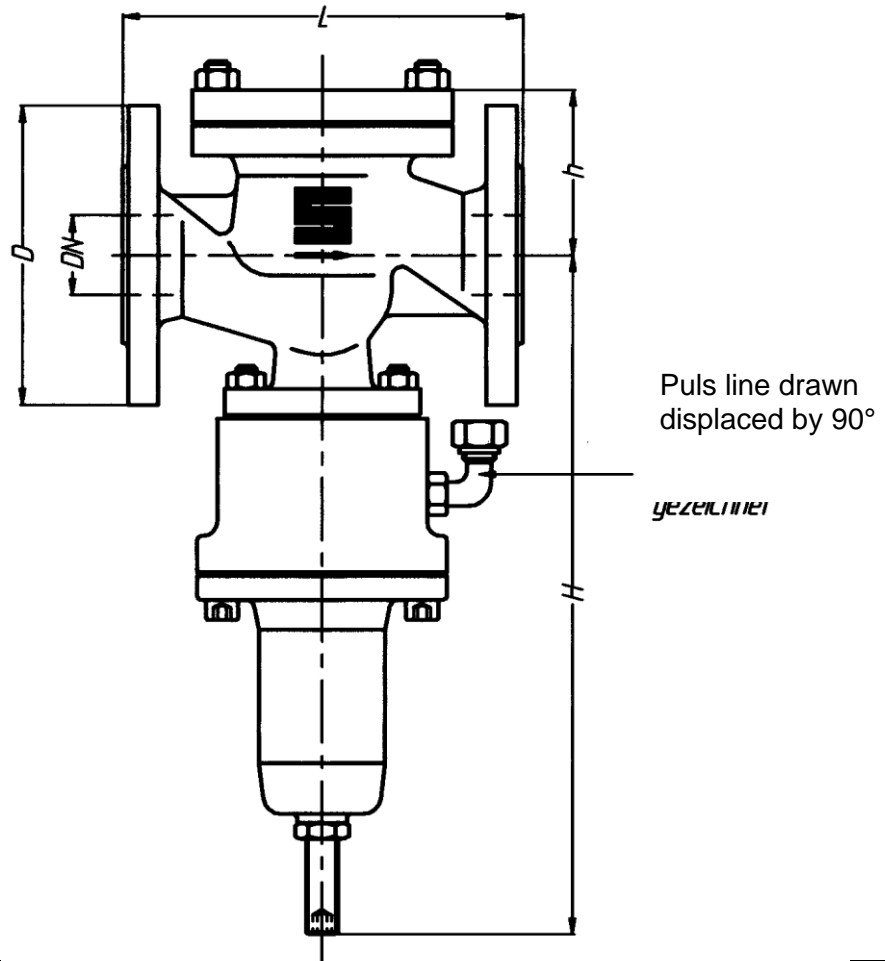

DN	Flanges PN16				Flanges PN40				L	H	h
	D	k	z	i	D	k	z	i			
15	95	65	4	14	95	65	4	14	130	310	90
20	105	75	4	14	105	75	4	14	150	310	90
25	115	85	4	14	115	85	4	14	160	310	90
32	140	100	4	18	140	100	4	18	180	330	120
40	150	110	4	18	150	110	4	18	200	330	120
50	165	125	4	18	165	125	4	18	230	435	130
65	185	145	4	18	185	145	8	18	290	465	155
80	200	160	8	18	200	160	8	18	310	630	180
100	220	180	8	18	235	190	8	23	350	655	180
125	250	210	8	18	270	220	8	26	400	660	210
150	285	240	8	22	300	250	8	26	480	680	235
200	340	295	12	22	375	320	12	29	600	740	285

Dimensions in mm

Installation lengths to EN 558-1

DN	15	20	25	32	40	50	65	80	100
GGG	10,5	10,5	12,0	14,5	15,5	28,5	37,0	56,5	69,0
GS/VA	12,5	12,5	13,5	16,0	18,5	32,5	40,0	66,0	78,0

Weights ~ kg/piece



# Pressure regulating valve T9

without auxiliary power, for liquids and gases  
DN15-200 PN16-40

Schley Armaturen GmbH  
VALVE MANUFACTURING  
Carl-Backhaus-Straße 3  
D-22926 Ahrensburg  
Tel: +49 4102 77883-0 • Fax: +49 4102 77883-99

## Mass flow graph for T9

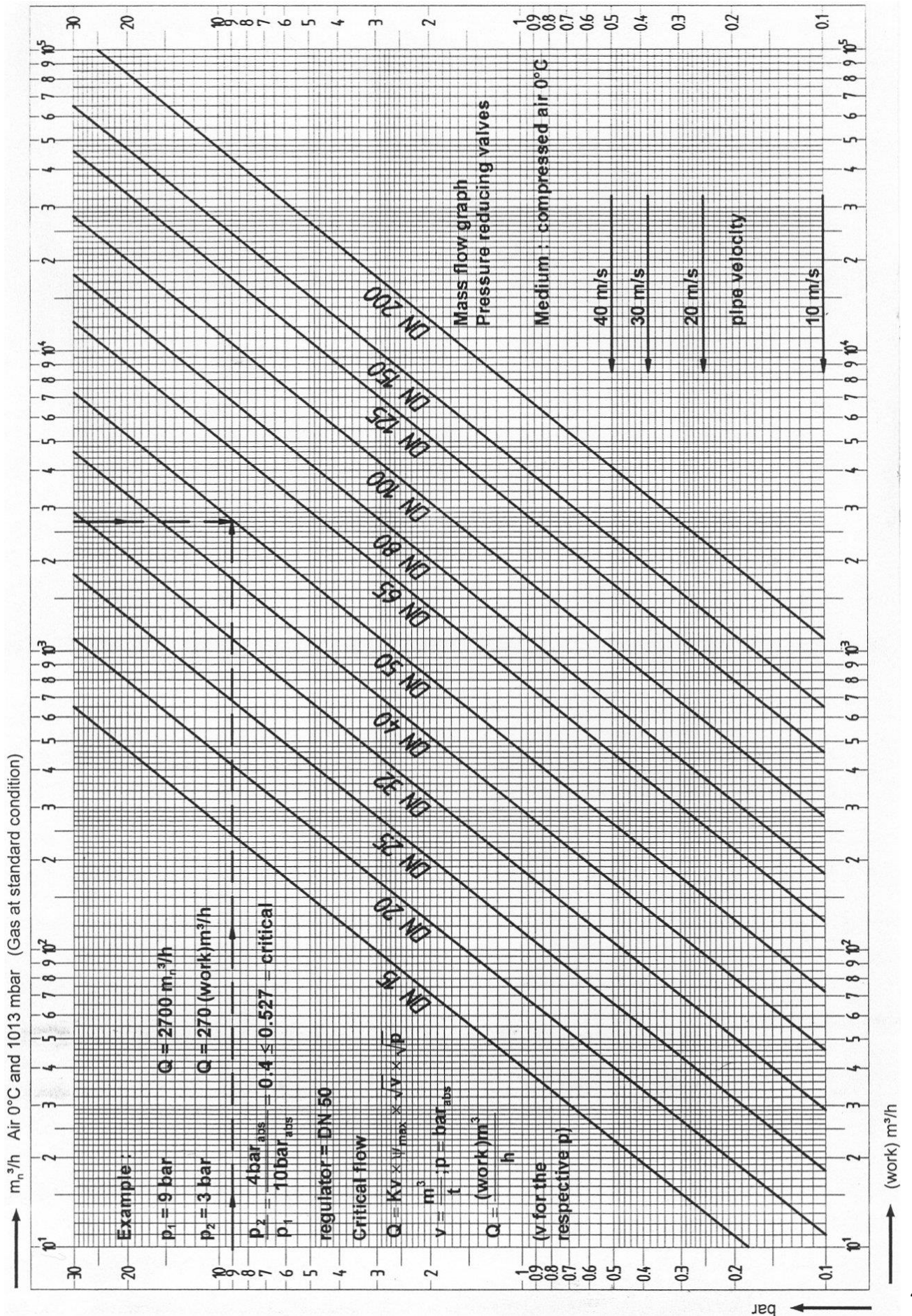



# Pressure regulating valve T9

without auxiliary power, for liquids and gases  
DN15-200 PN16-40

Schley Armaturen GmbH  
VALVE MANUFACTURING  
Carl-Backhaus-Straße 3  
D-22926 Ahrensburg  
Tel: +49 4102 77883-0 • Fax: +49 4102 77883-99

## Mass flow graph for T9

