

Operating and assembly instructions

Overflow valve

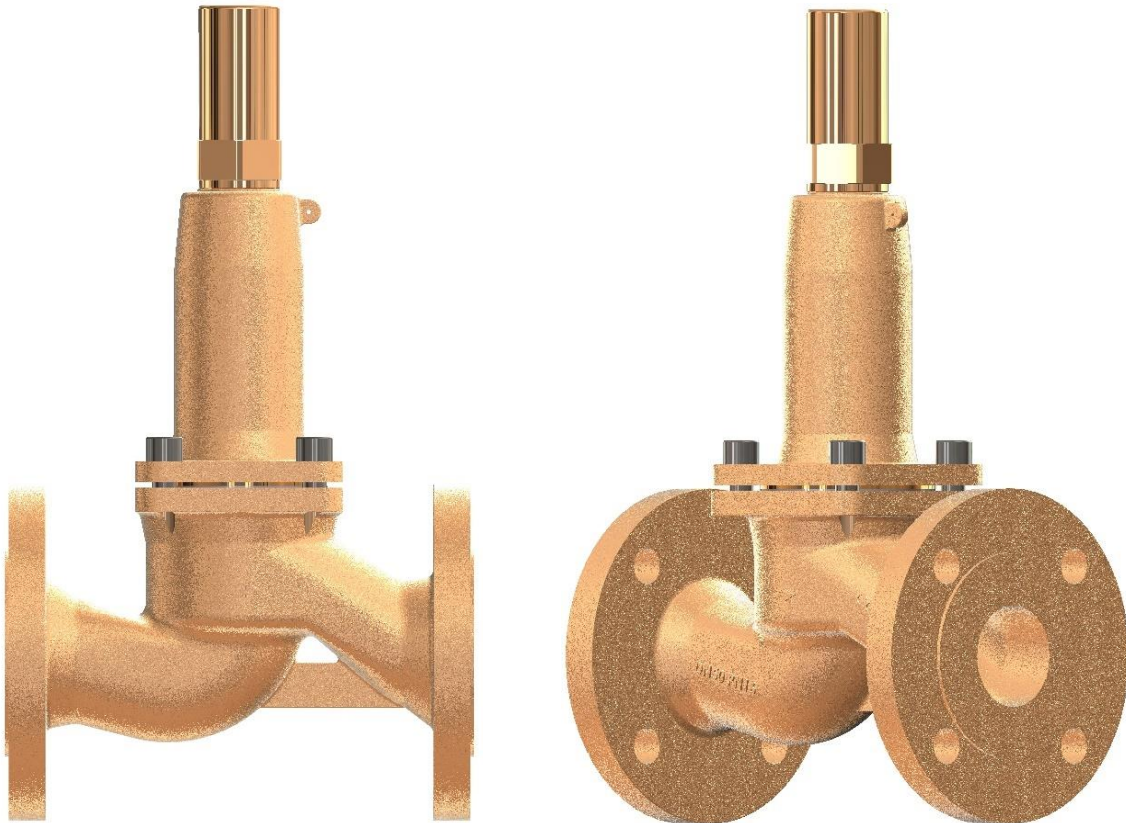

Table of contents

1.0 General information about the operating instructions.....	2	5.2 Strainer.....	7
2.0 Hazard statements	2	5.3 Safety valve	7
2.1 Meaning of symbols	2	6.0 Commissioning.....	8
2.2 Explanation of safety-related information	2	6.1 Instructions for setting.....	9
3.0 Storage and transport	3	6.1.1 Dismantling the cap	9
4.0 Description	3	6.1.2 Change of pressure "without" spring change.....	9
4.1 Scope	3	6.1.3 Change of the setpoint range "with" spring change	10
4.2 Operation	3	7.0 Care and maintenance	10
4.3 Diagram	4	8.0 Cause and remedy in the event of operational disruptions	11
4.3.1 Parts List	4	9.0 Troubleshooting Plan	11
4.4 Technical specification – Notes	5	10.0 Dismantling the valve.....	12
4.5 Marking.....	6	11.0 Guarantee / Warranty.....	12
5.0 Assembly.....	6		
5.1 General assembly information	6		

1.0 General information about the operating instructions

These operating instructions are used as instructions on how to safely install and maintain the valve. In case of difficulties that cannot be solved with the help of the operating instructions, contact the supplier or manufacturer.

These operating instructions are binding for transport, storage, assembly, commissioning, operation, maintenance and repair. The instructions and warnings must be observed and adhered to.

Handling and all other work must be carried out by competent personnel, or all activities must be supervised and checked.

The determination of the area of responsibility, the area of responsibility and the monitoring of the personnel is incumbent on the operator.

In the event of decommissioning, maintenance or repair, the current regional safety requirements must also be taken into account and observed.

The manufacturer reserves the right to make technical changes and improvements at any time.

These operating instructions comply with the requirements of the EU directives.

2.0 Hazard statements

2.1 Meaning of symbols

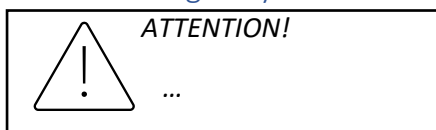

Warning of a general danger.

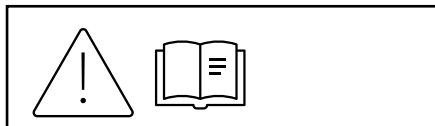

Danger in case of non-observance of the operating instructions!

Read and follow operating instructions before assembly, operation, maintenance or disassembly.

2.2 Explanation of safety-related information

In these operating and assembly instructions, particular attention is drawn to hazards, risks and safety-relevant information by means of a highlighted presentation.

Notices marked with a symbol listed above and "ATTENTION!" describe behavioral measures, the non-observance of which can lead to serious injury or danger to life for users or third parties or to material damage to the plant or the environment. They must be followed unconditionally, or compliance must be monitored.

However, observance of the other transport, assembly, operation and maintenance instructions as well as technical data (in the operating instructions, the product documentation and on the device itself) is equally essential in order to avoid disturbances that can directly or indirectly cause personal injury or property damage.

3.0 Storage and transport



ATTENTION!

- *Protect against external force (such as shock, vibration etc.).*
- *Valve superstructures such as control housings, bonnets and optionally handwheels must not be misused to absorb external forces such as climbing aids, connection points for hoisting gear, etc.*
- *Suitable means of transport and lifting must be used.*
- *Weight see data sheet.*

- From -20°C to +65°C.

4.0 Description

4.1 Scope

Overflow valves are used to "discharge excess capacity in pressurized systems". The valve has no safety function.



ATTENTION!

- *Areas of application, application limits and possibilities of use can be found in the data sheet.*
- *Certain media require or exclude special materials.*
- *The valves are designed for normal operating conditions. If the conditions go beyond these requirements, such as aggressive or abrasive media, the operator must specify the higher requirements when ordering.*
- *Valves made of grey cast iron are not approved for use in systems according to TRD 110.*

The specifications comply with the Pressure Equipment Directive 2014/68/EU.

Compliance is the responsibility of the plant designer.

Special markings of the valve must be observed.

The materials of the standard versions can be found in the data sheet.

If you have any questions, please consult the supplier or manufacturer.

4.2 Operation

The overflow valve is a valve that opens at a set inlet pressure or set pressure and closes automatically when it falls below it. The overflow function is controlled only by the spring force.

4.3 Diagram

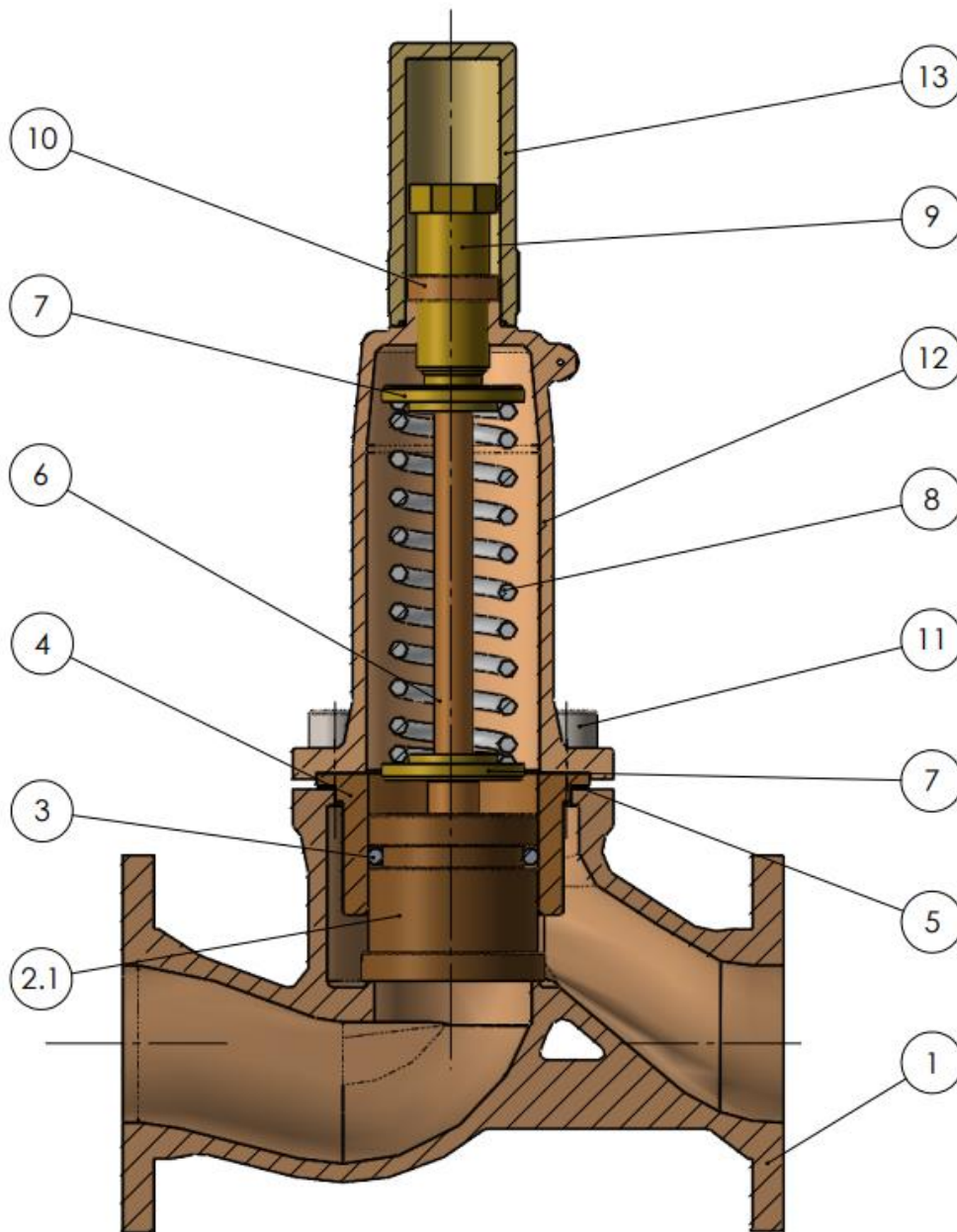

4.3.1 Parts List

Materials with designations and figure numbers can be found in the data sheet.

1	Valve body
2	Cone
3	O-ring
4	Guide sleeve
5	Gasket
6	Cone rod
7	Spring plate
8	Spring

9	Adjusting screw
10	Locking nut
11	*
12	Bonnet
13	Cap

*Depending on valve size hexagon socket screw or double end stud bolt with hexagon nut.



4.4 Technical specification – Notes

Such as:

- **Dimensions**
- **Pressure-temperature assignments etc.** can be found in the data sheet

Nominal diameter: DN15 - DN200

Pressure ratings: PN16, PN25, PN40, PN63, ANSI/ASME #150, ANSI/ASME #300,
ANSI/ASME #600

Temperature – valve: according to pressure-temperature table see data sheet

Materials:

Body	Internal parts
CC480K	CC483K / CC493K
CC333G	CW307G

Gasket (O-ring): EPDM, NBR, FKM

Temperature range:

EPDM	-50 bis +140°C
NBR	-25 bis +120°C
FKM	-40 bis +200°C

Cone seal:

metal	steam and liquids
soft gasket	gases

4.5 Marking

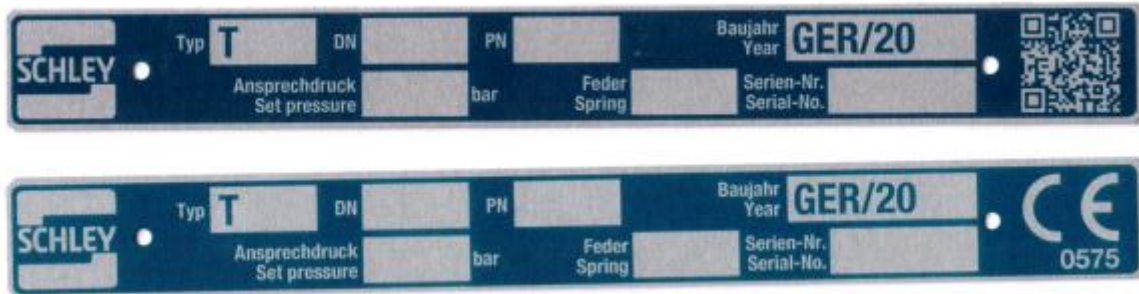

Address of the manufacturer: see point 11.0 Guarantee / Warranty

In accordance with the Pressure Equipment Directive Diagram 6, Annex II, valves without a safety function may only be CE marked from DN32 onwards.

5.0 Assembly

5.1 General assembly information

In addition to the generally applicable installation guidelines, the following points must be observed:



ATTENTION!

- Remove flange covers, if any.
- The interior of the valve and pipeline must be free of foreign particles.
- Pay attention to the installation position with regard to the flow through see → marking on the valve.
- Steam piping systems shall be designed in such a way as to avoid water retention.
- Lay the piping in such a way that harmful shearing, bending and torsional forces are kept away.
- During construction work, protect valves from contamination.
- Connection flanges must match.
- Connecting screws for pipeline flanges are preferably mounted from the counter flanges (6kt nuts from the valve side).
- Valves structures such as control housing, bonnets and optional handwheels must not be used to absorb external forces such as climbing aids, connection points for hoisting gear, etc. be misused.
- Suitable means of transport and lifting must be used for assembly work.
Weight see data sheet
- Freezing, sticking or blocking of the overflow valve must be avoided at all costs (e. g. by heating)
- Before resetting, the cap must be carefully opened to intercept any medium that has collected in the cap.
- **Overflow valves do not perform a safety function!**

- Planners / construction companies or operators are responsible for the positioning and installation of the products.
- The valves are designed for use in weather-protected systems.
- For use in free-standing areas or in particularly unfavourable environmental conditions, such as corrosion-promoting conditions (seawater, chemical vapours, etc.), special designs or protective measures are recommended.
- The system must be flushed before installing the overflow valve to remove contaminants that could damage the cone/seating area or clog control holes.
- Center seals between the flanges.
- The overflow valve must be installed upright (hood close to the top).

5.2 Strainer



ATTENTION!

A strainer should be installed in front of the overflow valve. This should be cleaned at regular intervals.

5.3 Safety valve



ATTENTION!

The system must be protected against inadmissible overpressure. The safety valve required for this purpose must be designed in such a way that it can dissipate the maximum possible mass flow. The set pressure depends on the part of the system with the lowest pressure capacity, whereby there must be a sufficiently large distance between the set pressure and the system pressure.

If necessary, the inlet pressure (p_1) and the pressure downstream of the overflow valve (p_2) must be equipped with a safety valve.

6.0 Commissioning



ATTENTION!

- Before commissioning the information on material, pressure, temperature and flow direction must be checked.
- In principle the regional safety instructions must be observed.
- Residues in pipes and valve (such as dirt, welding beads, etc.) lead to leaks or damage.
- When operating with high (> 50 °C) or low (< 0 °C) media temperatures, there is a risk of injury if the valve is touched.
If necessary, attach warnings or insulation.
- Overflow valves do not perform a safety function.
- Freezing, sticking or blocking of the overflow valve must be avoided at all costs (e. g. by heating)
Before each commissioning of a new plant or recommissioning of a plant after repairs or conversions, the following must be ensured:
 - The proper completion of all work.
 - The correct functional position of the valve.
 - Guards are fitted.

The Commissioning then takes place as follows:

- Carefully open the shut-off valve in front of the overflow valve.
- Dismantle the cap (see point 6.1.1).
- Adjust the pressure screw (see point 6.1.2) until the desired set pressure is reached.

As a rule, the overflow valve discharges the required flow rate, with a corresponding increase in pressure above the set pressure.

6.1 Instructions for setting

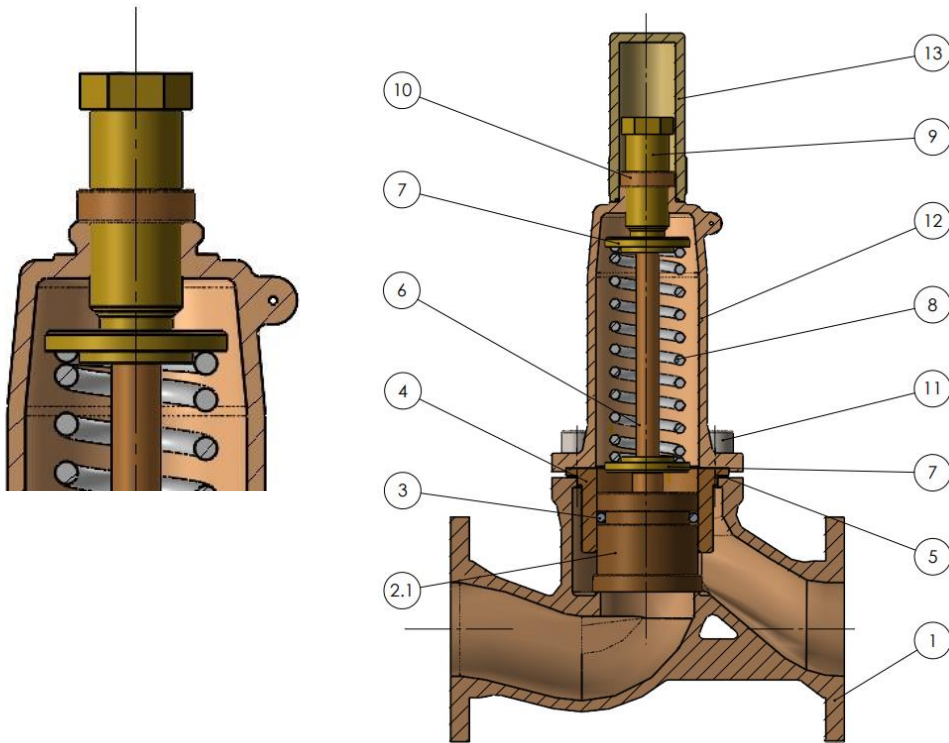

6.1.1 Dismantling the cap



ATTENTION!

During adjustment work, medium may leak from the pressure screw (item 9).

Unscrew the cap (pos. 13) and pay attention to any leaking medium.

6.1.2 Change of pressure "without" spring change

- Pay attention to the adjustment range of the spring
- Loosen locking nut (pos. 10)
- Increasing the pressure by turning it to the right and lowering the pressure by turning the adjusting screw to the left (pos. 9) (only adjustable when the medium is flowing)
- Secure spring adjustment by countering with lockingnut (pos. 10)
- Mounting the cap (pos. 13)

6.1.3 Change of the setpoint range "with" spring change

	<p>ATTENTION!</p> <p><i>Before dismantling, the system must be depressurized! (see point 10.0)</i></p>
---	---

- Loosen the locking nut (pos. 10) and relax the spring (item 8) by turning the adjusting screw (pos. 9) to the left.
- Loosen the hexagon nuts or hexagon socket screws (pos. 11) of the flange connection and remove the bonnet (pos. 12)

	<p>ATTENTION!</p> <p><i>At higher pressures, the hexagon nuts / hexagon socket screws (pos. 11) must be carefully removed!</i></p>
---	---

- Remove the upper spring plate (pos. 7) and spring (pos. 8).
- Insert another spring (pos. 8) and upper spring plate (pos. 7).
- Replace gaskets.
- Mount bonnet (pos. 12); Center the upper spring plate (pos. 7) and spring (pos. 8) to the adjusting screw (pos. 9). Then adjust the pressure when the medium is flowing, pay attention to the adjustment range of the spring (see point 6.0 Start-up).
- Secure spring adjustment by countering with locking nut (pos. 10).
- Assemble the cap (pos. 13).

	<p>ATTENTION!</p> <p><i>Torques must be adhered to:</i></p> <table style="margin-left: auto; margin-right: auto;"> <tr> <td style="padding-right: 20px;"><i>M10</i></td> <td><i>16-25 Nm</i></td> </tr> <tr> <td style="padding-right: 20px;"><i>M12</i></td> <td><i>30-40 Nm</i></td> </tr> <tr> <td style="padding-right: 20px;"><i>M16</i></td> <td><i>70-90 Nm</i></td> </tr> </table>	<i>M10</i>	<i>16-25 Nm</i>	<i>M12</i>	<i>30-40 Nm</i>	<i>M16</i>	<i>70-90 Nm</i>
<i>M10</i>	<i>16-25 Nm</i>						
<i>M12</i>	<i>30-40 Nm</i>						
<i>M16</i>	<i>70-90 Nm</i>						

7.0 Care and maintenance

The maintenance and maintenance intervals are to be determined by the operator according to the conditions of use. However, a visual inspection should take place after one year at the latest and the valve should be completely checked after two years. Here, the manufacturer recommends replacing all seals and o-rings of the valve for material fatigue in order to prevent leaks.

When dismantling the valve, the gaskets must always be replaced.

For the reordering of the seals, please always enter the details of the type plate in order to ensure an assignment of the valve.

Leaks due to damage to the seat/cone sealing surface must be removed in our factory or an authorized specialist company.

To change the pressure or change the setpoint range plus spring change, always follow our adjustment instructions (point 6.0).

8.0 Cause and remedy in the event of operational disruptions

In the event of malfunctions or operating behaviour, it must be checked whether the assembly work has been carried out and completed in accordance with these instructions.

	<p>ATTENTION!</p> <p><i>When troubleshooting, safety regulations must be followed.</i></p>
---	---

In the event of malfunctions that cannot be remedied on the following table, see point "9.0 Troubleshooting Plan", the supplier or manufacturer must be contacted.

9.0 Troubleshooting Plan

	<p>ATTENTION!</p> <ul style="list-style-type: none"> - Observe points 10.0 and 11.0 before assembly and repair work! - Please note point 6.0 before recommissioning!
---	---

Disturbance	Possible causes	Remedy
No flow	Flange covers have not been removed.	Remove flange covers.
Too low flow	Contaminated strainer.	Clean / replace the sieve.
	Blockage in the piping system.	Check the piping system.
Overflow valve does not respond, no flow	Setting pressure too high.	Adjust the overflow valve according to point 6.0.
	Tough or sticky media.	Using a heating jacket.
	To secure the housings and cables against freezing or solidification of the medium.	Using a heating jacket.
	Overflow valve installed in the wrong direction.	Install the overflow valve in the direction of the arrow.
Overflow valve leaking in the seat	Overflow valve has rattled.	See point „Rattling“.
	Contaminated medium, foreign body between seat and cone.	Replacing the overflow valve.
Flange breakage	Damage in transit.	Replacing the overflow valve.
	Flanges tightened on one side.	Replacing the overflow valve.
	Transmitting inadmissible forces such as bending or torsional forces.	Tension-free installation.
Overflow valve remains open at all times	Spring blocked or broken.	Replacing the overflow valve.
	Spindle guide corroded.	Replacing the overflow valve.
„Rattling“	Overflow valve that is too large.	Choose a smaller overflow valve.
Too low power	Overflow valve incorrectly designed for the system conditions.	Redesign and replace the overflow valve.

10.0 Dismantling the valve



ATTENTION!

In particular, the following points should be noted:

- *Unpressurized piping system*
- *Cooled medium*
- *Emptied plant*
- *In case of corrosive, flammable, aggressive or toxic media, ventilate the piping system*
- *Please wear the necessary personal protective equipment (PPE)*

11.0 Guarantee / Warranty

The scope and period of warranty is specified in the edition of the "General Terms and Conditions of Schley Armaturen GmbH" valid at the time of delivery or deviating from this in the purchase contract itself.

We warrant freedom from defects in accordance with the current state of the art and the confirmed intended use.

No warranty claims can be asserted for damages caused by improper handling or non-observance of the operating and assembly instructions, the data sheet and the relevant regulations.

Justified complaints will be remedied by rework by us or by specialist companies commissioned by us.

Claims beyond the warranty are excluded. There is no entitlement to a replacement delivery.

Maintenance work, installation of third-party parts, changes in design and natural wear and tear are excluded from the warranty.

Any transport damage must not be reported to us, but immediately to your responsible goods handling, the railway or the freight forwarder, otherwise claims for compensation against these companies will be lost.



Schley Armaturen GmbH
Carl-Backhaus - Straße 3
22926 Ahrensburg, Germany
Phone: +49 (0) 4102 77883-0 Fax: +49 (0) 4102 77883-99
info@schley-armaturen.de